

GREENWICH

BEING A REPLAT OF A PORTION OF TRACT "WK5-A", AS SHOWN ON ABACOA - REPLAT OF TRACT WK5 AS RECORDED IN PLAT BOOK 85, PAGES 7 AND 8 OF THE PUBLIC RECORDS OF PALM BEACH COUNTY, FLORIDA. LYING IN SECTION 24, TOWNSHIP 41 SOUTH, RANGE 42 EAST TOWN OF JUPITER, PALM BEACH COUNTY, FLORIDA.

AUGUST 2004
SHEET 4 OF 4

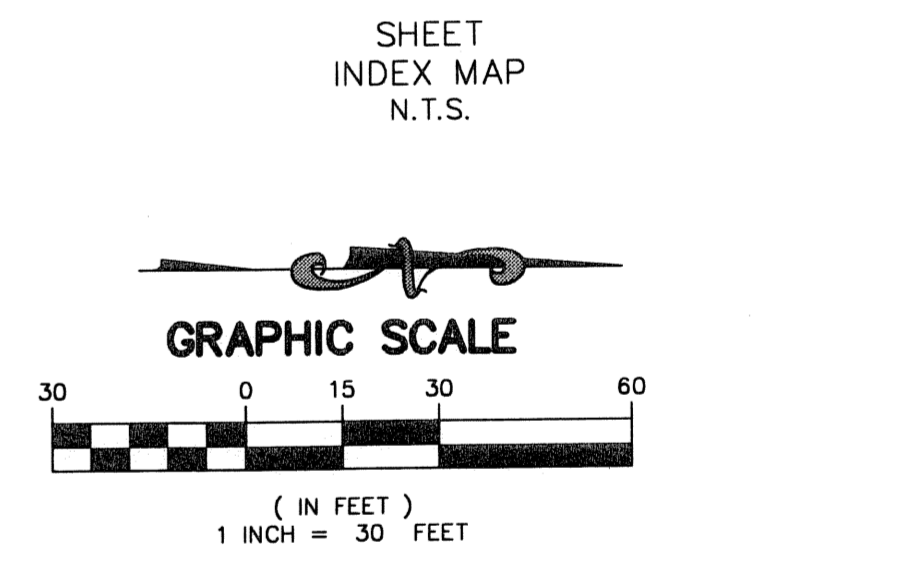
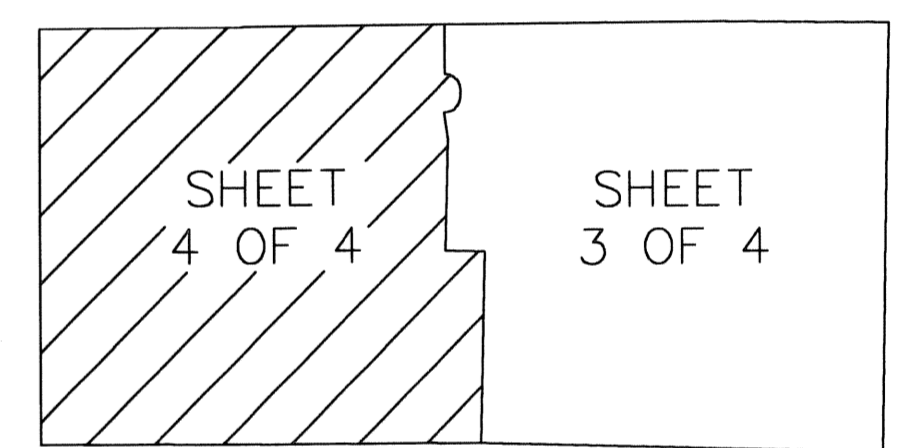

- ABBREVIATIONS:
1. D = DELTA (CENTRAL ANGLE)
 2. R = RADIUS
 3. L = ARC LENGTH
 4. CB = CHORD BEARING
 5. CD = CHORD DISTANCE
 6. □ = PERMANENT REFERENCE MONUMENT LB 6680 SET UNLESS OTHERWISE NOTED
 7. * = PERMANENT CONTROL POINT LB 6680 SET UNLESS OTHERWISE NOTED
 8. PUD = PLANNED UNIT DEVELOPMENT
 9. LB = LICENSED BUSINESS
 10. LAE = LIMITED ACCESS EASEMENT
 11. U.E. = UTILITY EASEMENT
 12. S.W.E. = SIDEWALK EASEMENT
 13. LB = LICENSED BUSINESS
 14. CB = CURVE BEARING
 15. CD = CURVE DISTANCE
 16. SSE = STREET & RIGHT-OF-WAY INTERSECTION
 17. DE = DRAINAGE EASEMENT

MILLER LEGG
 & ASSOCIATES, INC.
 Engineers • Planners
 Land Surveyors
 Environmental Professionals
 LICENSED BUSINESS NUMBER 6680

2005 Vista Parkway
 Suite 100
 West Palm Beach,
 Florida 33411-2719
 (561) 689-1138
 Fax: (561) 689-8108

ABACOA PLAT NO. 1
 TRACT GW4
 (PLAT BOOK 78,
 PAGES 145 THROUGH 163)

STREET &
 RIGHT-OF-WAY
 INTERSECTION
 (TYPICAL)

ABACOA PLAT NO. 1
 TRACT GW9
 (PLAT BOOK 78,
 PAGES 145 THROUGH 163)

LOT 317
 NEWHAVEN - 7B
 PHASE 2 AT ABACOA
 (PLAT BOOK 89,
 PAGES 100 THROUGH 105)

MATCHLINE
 SEE SHEET 3 OF 4

MATCHLINE
 SEE SHEET 3 OF 4